

Features

- Low Forward Voltage
- Epitaxial Construction with Oxide Passivation
- Guard Ring for Transient and ESD Protection
- Surge Overload Rating to 100A Peak
- Low Power Loss
- Fast Switching
- Ideally Suited for Use in High Frequency SMPS, Inverters and As Free Wheeling Diodes

SMB /DO-214AA

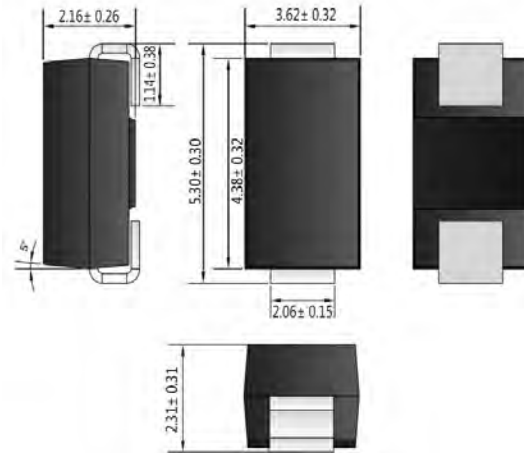

Mechanical Data

- Case: SMB/DO-214AA, Molded Plastic
- Terminals: Solder Plated, Solderable per MIL-STD-750, Method 2026
- Polarity: Cathode Band or Cathode Notch
- Marking: Type Number
- Weight: 0.093 grams (approx.)
- **Lead Free: For RoHS / Lead Free Version**

Maximum Ratings @ $T_A=25^{\circ}\text{C}$ unless otherwise specified

Characteristic	Symbol	SR32	SR33	SR34	SR35	SR36	SR38	SR39	SR310	Unit	
Peak Repetitive Reverse Voltage	V_{RRM}										
Working Peak Reverse Voltage	V_{RWM}	20	30	40	50	60	80	90	100	V	
DC Blocking Voltage	V_R										
RMS Reverse Voltage	$V_{R(RMS)}$	14	21	28	35	42	56	63	70	V	
Average Rectified Output Current (Note 1)	I_O	3.0								A	
Non-Repetitive Peak Forward Surge Current 8.3ms Single Half Sine-Wave Superimposed on Rated Load (JEDEC Method)	I_{FSM}	60								A	
Forward Voltage @ $I_F = 3.0\text{A}$	V_{FM}	0.50			0.62		0.85			V	
Peak Reverse Current @ $T_J = 25^{\circ}\text{C}$ At Rated DC Blocking Voltage @ $T_J = 100^{\circ}\text{C}$	I_{RM}					0.5 20					mA
Typical Junction Capacitance (Note 2)	C_J	250			180		140			pF	
Thermal Resistance, Junction to Ambient (Note 1)	R_{JA}	75								°C/W	
Thermal Resistance, Junction to Case (Note 1)	R_{JC}	20									
Operating Temperature Range	T_J	-55 to +125				-55 to +150				°C	
Storage Temperature Range	T_{STG}	-55 to +150								°C	

Note: 1. Mounted on FR-4 PCB with 8.0 x 8.0mm copper pads.
2. Measured at 1.0 MHz and applied reverse voltage of 4.0V D.C.

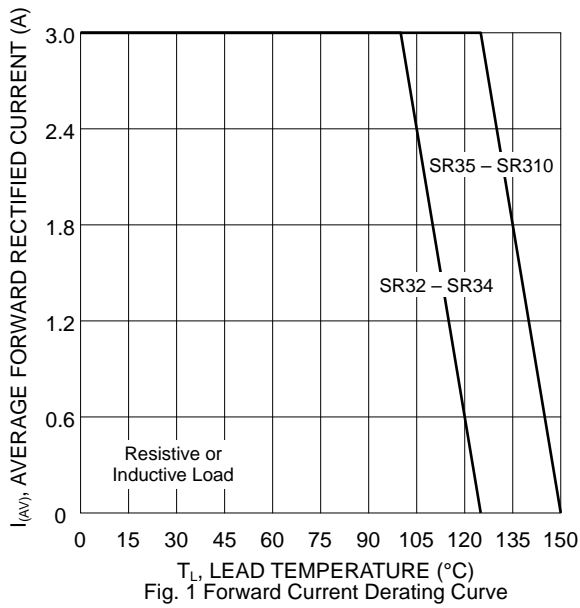

Fig. 1 Forward Current Derating Curve

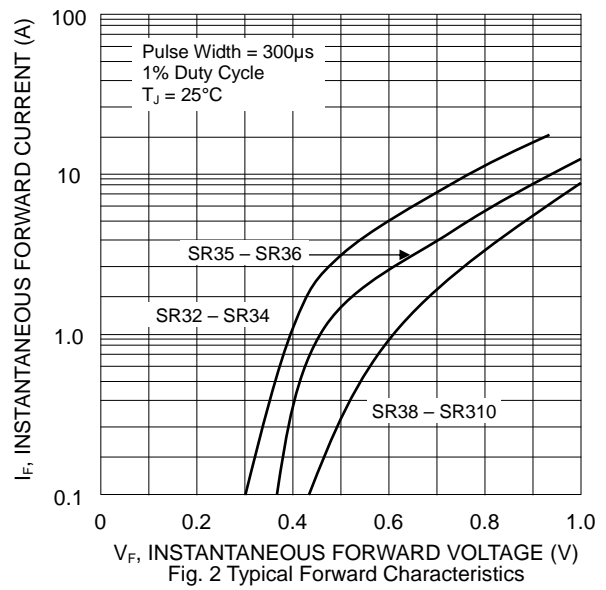

Fig. 2 Typical Forward Characteristics

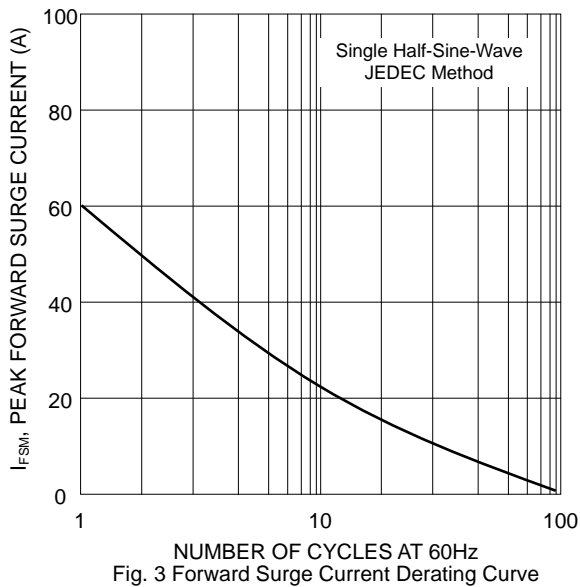

Fig. 3 Forward Surge Current Derating Curve

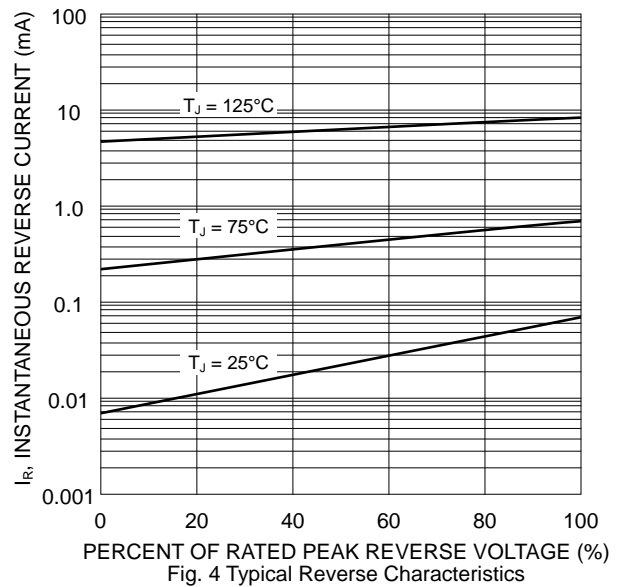

Fig. 4 Typical Reverse Characteristics

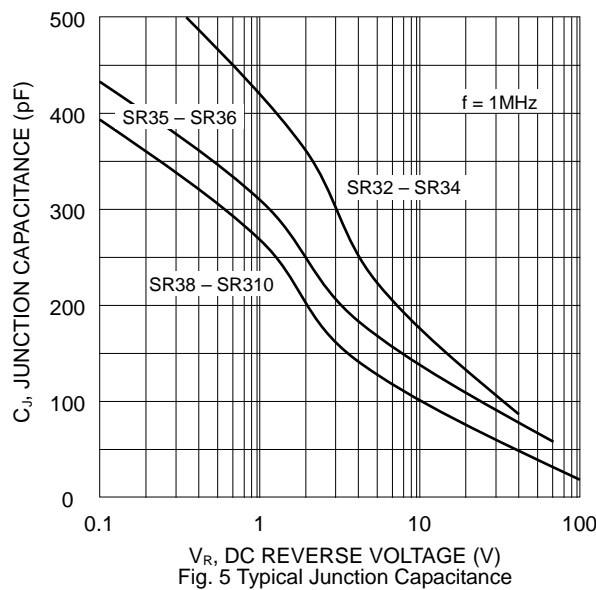

Fig. 5 Typical Junction Capacitance

MARKING INFORMATION



SR3x = Device Number
 x = 2, 3, 4, 5, 6, 8, 9 or 10

RECOMMENDED FOOTPRINT

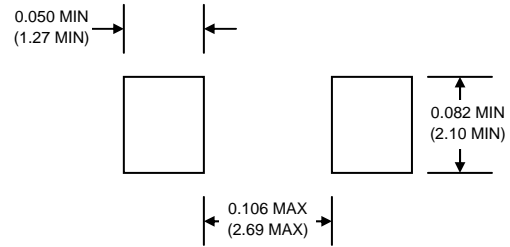

inches(mm)

PACKAGING INFORMATION

TAPE & REEL

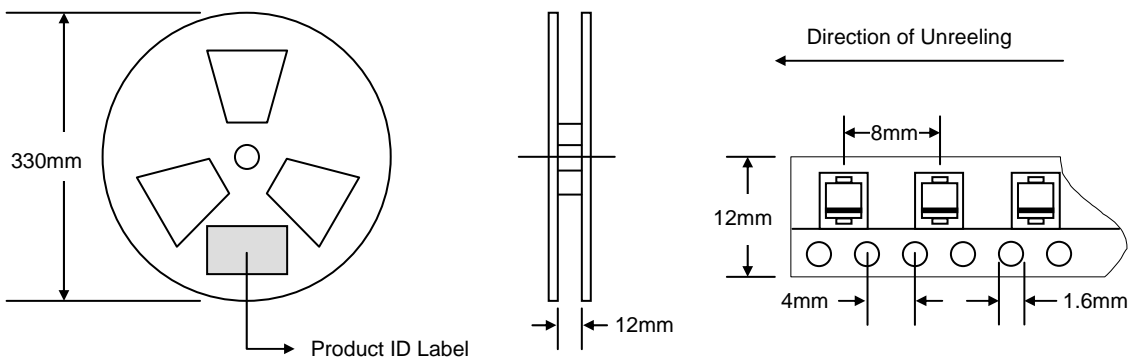

Reel Diameter (mm)	Quantity (PCS)	Inner Box Size L x W x H (mm)	Quantity (PCS)
330	3,000	340 x 337 x 45	6,000

NOTICE

Leiditech reserves the right to make modifications, enhancements, improvements, corrections or other changes without further notice to any product herein. Leiditech does not assume any liability arising out of the application or use of any product described herein.

Shanghai Leiditech Electronic Co.,Ltd
 Email: sale1@leiditech.com
 Tel : +86- 021 50828806
 Fax : +86- 021 50477059